



PLATINUM 4000
(Standard)



PLATINUM 6000
(Heavy duty)



PLATINUM 9000
(Heavy duty floor to ceiling)

INTRODUCTION

- Platinum Cavity is a steel cavity door unit that provides you with more strength, space and design choice. There is a wide selection of widths and heights across three unit configurations which can suit a range of applications, including floor to ceiling and tiled wet areas.



Rolled steel cross section
(Galvanised angle shown)



Bumper Stops

10mm Bumper Stop required for flush jamb applications.
60mm Bumper Stop required for flush pull applications.

KEY FEATURES

- Steel construction ensures resistance to warp/bow, white ant and rot.
- Rolled steel sections provide additional strength.
- Independently assessed to be fit-for-purpose for tiled wall applications.*
- Ability to carry taller, wider and heavier doors.
- All Platinum Cavity units are supplied with 2 kinds of rubber bumper stops to achieve flush jamb or flush pull configurations. 2 x 10mm bumper stops are used to achieve a flush jamb configuration. 1 x 60mm bumper stop to achieve a flush pull configuration.
- In flush jamb applications a Jexis press-release unit can be incorporated making it easier to retrieve the door from the cavity pocket.
- Designed for domestic and commercial applications.
- 5 year warranty – terms and conditions apply.



Jexis press-release unit

(Sold separately - suitable for flush jamb applications only)

*For further information, contact your Corinthian sales representative.

PLATINUM CAVITY UNITS

PLATINUM 4000 STANDARD

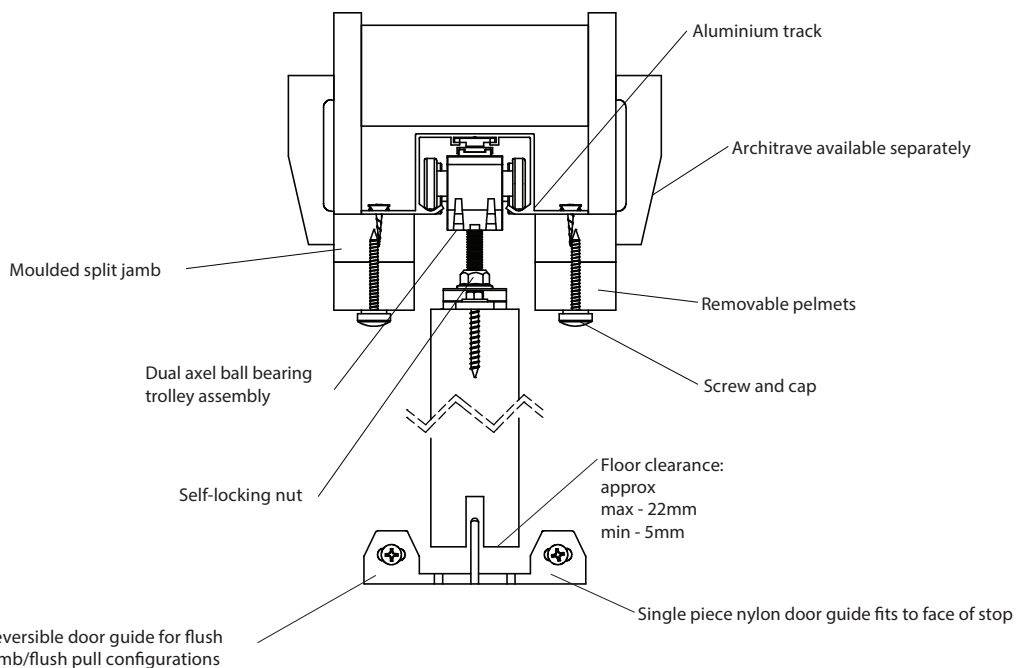
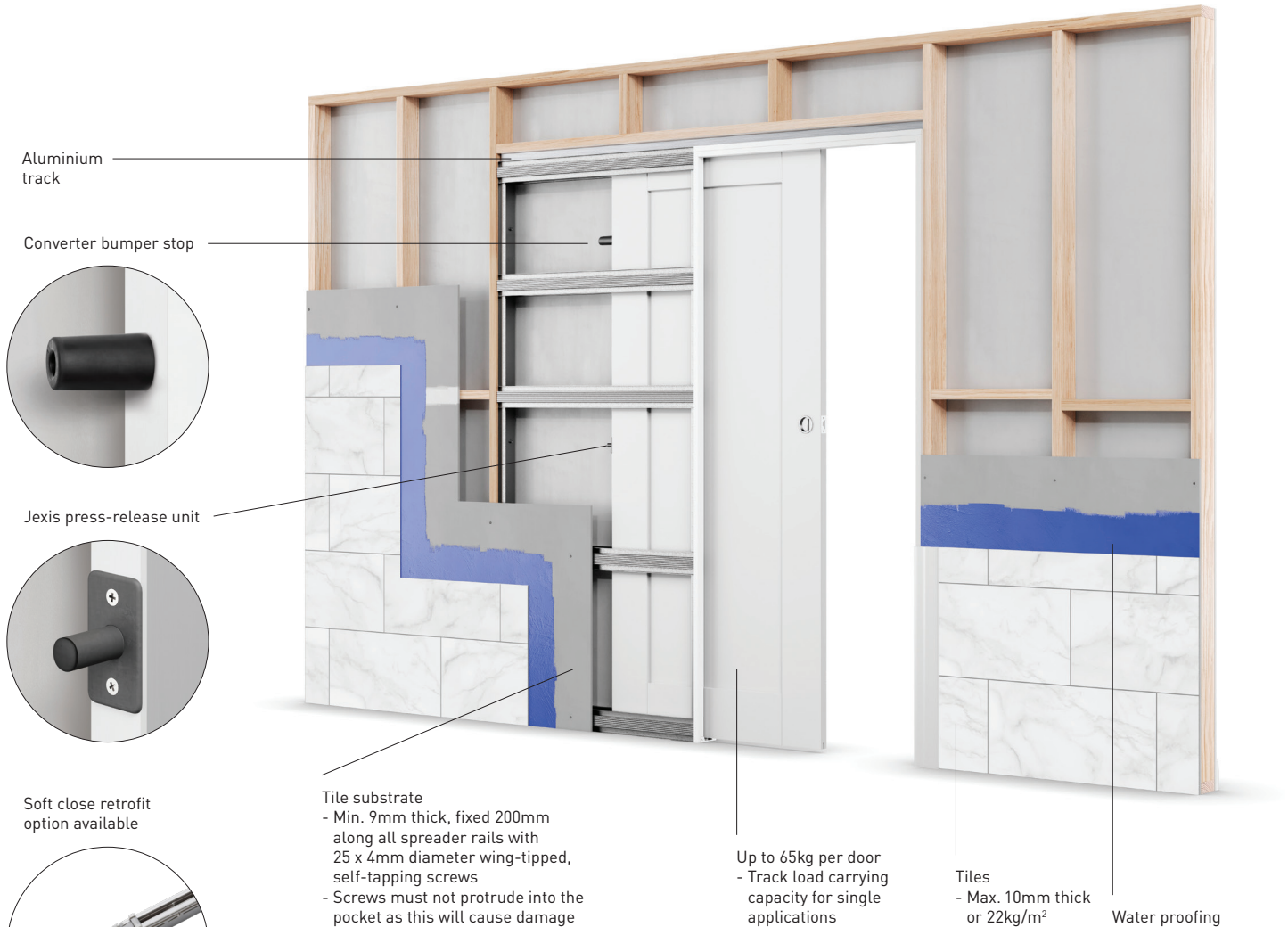

PLATINUM CAVITY UNITS

PLATINUM 6000 HEAVY DUTY

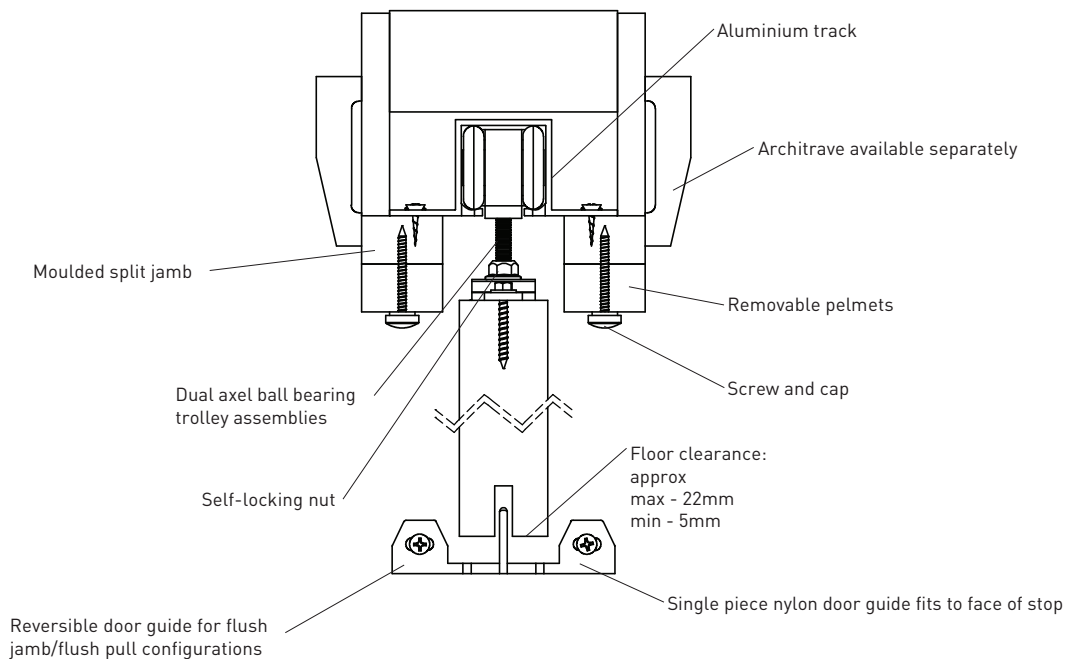
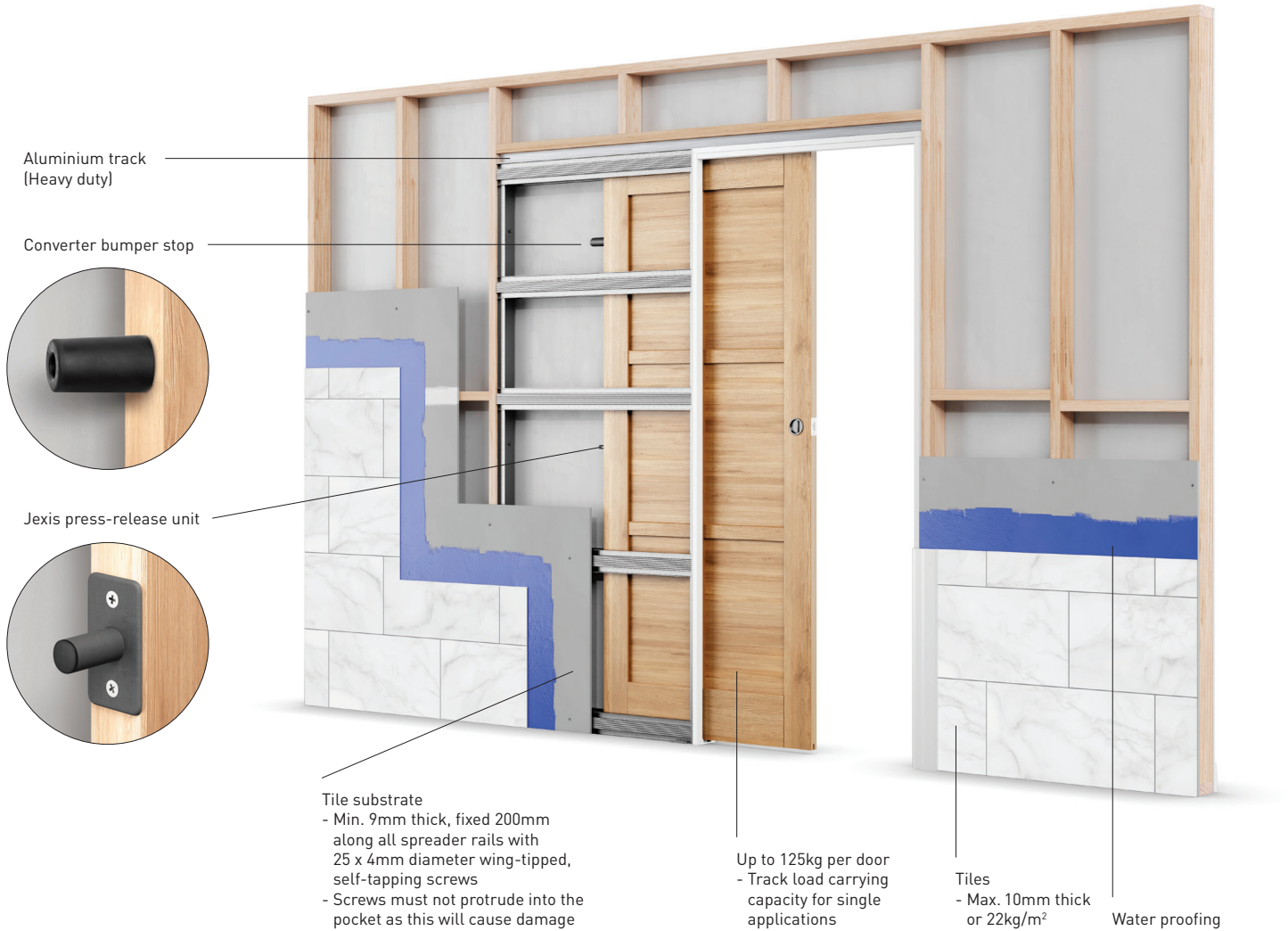

PLATINUM CAVITY UNITS

PLATINUM 9000 HEAVY DUTY FLOOR TO CEILING

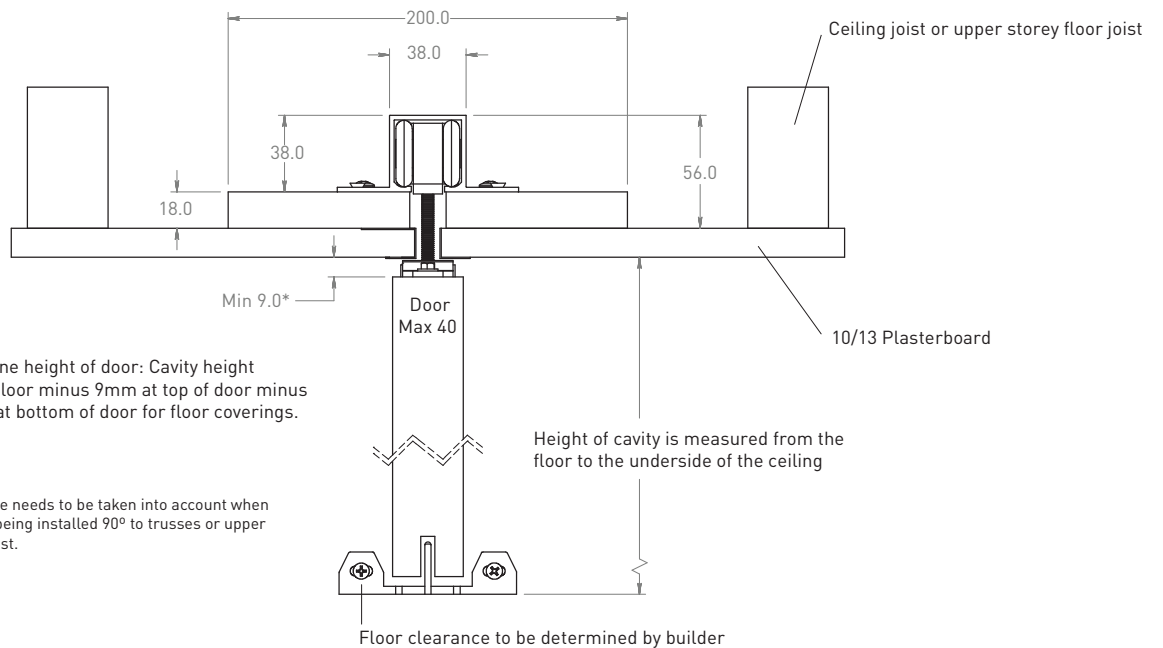
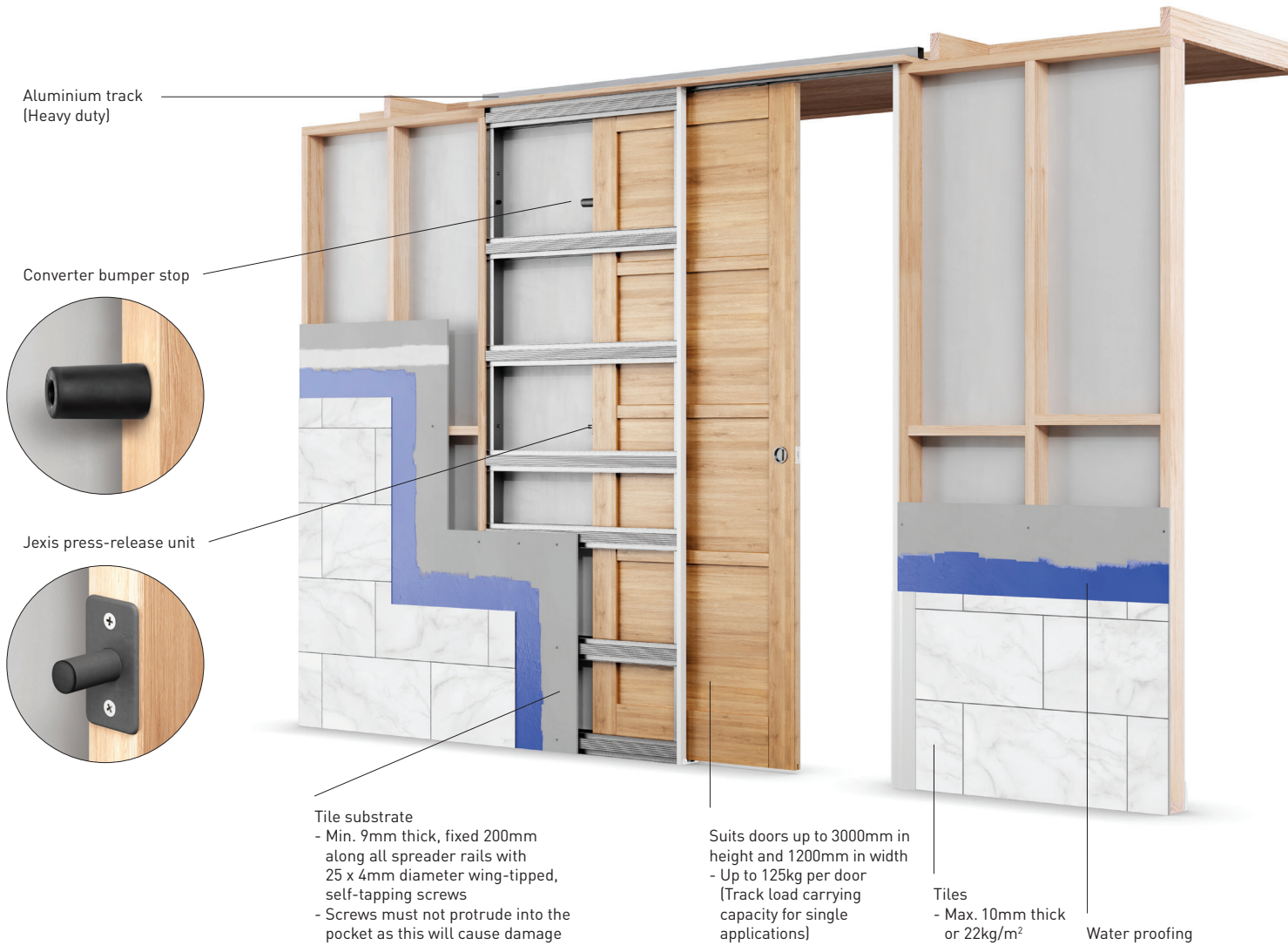

SPECIFICATIONS

	PLATINUM 4000 (STANDARD)	PLATINUM 6000 (HEAVY DUTY)	PLATINUM 9000 (HEAVY DUTY FLOOR TO CEILING)
Features	<ul style="list-style-type: none"> - Jump proof twin roller track - Steel construction eliminates issues with white ants or moisture - Unique metal clinching assembly method and rolled steel sections provide additional strength - Soft close retrofit option available - Single unit allows for flush jamb or flush pull configurations 	<ul style="list-style-type: none"> - Jump proof twin roller track - Steel construction eliminates issues with white ants or moisture - Unique metal clinching assembly method and rolled steel sections provide additional strength - Single unit allows for flush jamb or flush pull configurations 	<ul style="list-style-type: none"> - Custom made to suit specific ceiling heights - Jump proof twin roller track - Steel construction eliminates issues with white ants or moisture - Unique metal clinching assembly method and rolled steel sections provide additional strength - Single unit allows for flush jamb or flush pull configurations
Roller system	Dual axle ball bearings for smooth running.	Dual axle ball bearings for smooth running.	Dual axle ball bearings for smooth running.
Tracks	- Standard track (Aluminium)	- Heavy duty track (Aluminium)	- Heavy duty track (Aluminium)
Track load carrying capacity	Single applications - Up to 65kg per door Double applications - Up to 45kg per door	Single applications - Up to 125kg per door Double applications - Up to 85kg per door	Single applications - Up to 125kg per door Double applications - Up to 85kg per door
Cavity inclusions	<ul style="list-style-type: none"> - 1 x cavity pocket - 1 x head track assembly - 2 x removable fillets - 1 x closing jamb - 1 x hardware pack: <ul style="list-style-type: none"> - 1 x trolley kit - 1 x screw pack - 1 x glide guide kit^ - 2 x 10mm Bumper Stops required for flush jamb applications - 1 x 60mm Bumper Stop required for flush pull applications 	<ul style="list-style-type: none"> - 1 x cavity pocket - 1 x head track assembly - 2 x removable fillets - 1 x closing jamb - 1 x hardware pack: <ul style="list-style-type: none"> - 1 x trolley kit - 1 x screw pack - 1 x glide guide kit^ - 2 x 10mm Bumper Stops required for flush jamb applications - 1 x 60mm Bumper Stop required for flush pull applications 	<ul style="list-style-type: none"> - 1 x cavity pocket - 1 x head track assembly - 2 x removable fillets - 1 x closing jamb - 1 x hardware pack: <ul style="list-style-type: none"> - 1 x trolley kit - 1 x screw pack - 1 x glide guide kit^ - 2 x 10mm Bumper Stops required for flush jamb applications - 1 x 60mm Bumper Stop required for flush pull applications
Installation	When installing in wet areas make allowance for tiles or other floor coverings. Cavity units are not load bearing. Refer to - Corinthian's Cavity Installation Instructions for more information. Failure to adhere to these instructions will void warranty.		
Warranty	5 Years - Terms and conditions apply - refer to Warranty and Terms and Conditions of Sale.		
Special sizes	Prices and lead-times upon application. Cavities will be Made to Order. For further information contact Corinthian Customer Service.		
Made To Order (MTO)	All Cavities are Made To Order (MTO). MTO cavities may only be cancelled on day of ordering.		
Note	All sizes are nominal and in millimetres.		

^QLD, NSW & WA only

HARDWARE PACK INCLUSIONS



SPECIFICATIONS

STUD OPENING HEIGHTS & WIDTHS

DOOR HEIGHT	OPENING HEIGHT (MM)	
	PLATINUM 4000	PLATINUM 6000
2040	2130	2140
2340	2430	2440

DOOR WIDTH	OPENING WIDTH (MM)	
	SINGLE	DOUBLE
620	1300	2550
720	1500	2950
770	1600	3150
820	1700	3350
870	1800	3550
920	1900	3750
1020	2100	4150*
1200	2460*	4870*

*Only available in Platinum 6000. Platinum 9000 units are custom made up to 3000mm in height and 1200mm in width.

SINGLE UNIT - FLUSH JAMB AND FLUSH PULL

FLUSH JAMB

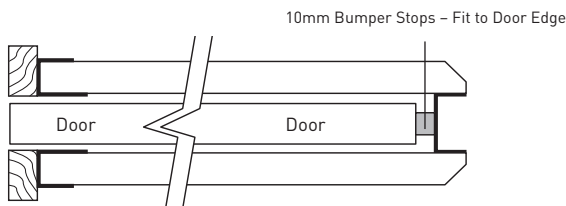

- A single Platinum Cavity Unit allows you to achieve both flush jamb or flush pull configurations.
- 2 x 10mm bumper stops are used to achieve a flush jamb configuration. 1 x 60mm bumper stop to achieve a flush pull configuration.
- All bumper stops and required fixings are included in the Platinum Cavity hardware pack as standard.
- In both flush jamb and flush pull configurations, bumper stops are installed to the back edge of the door prior to installing the door within the cavity.

FLUSH PULL

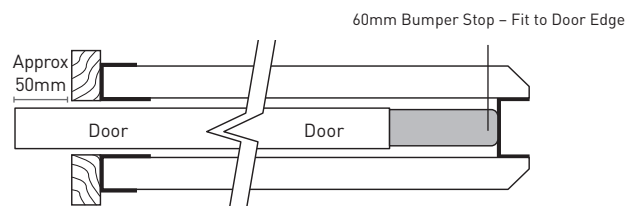

*Platinum Cavity with door in fully open position.